

Chapter 1

1. Consider an aluminum single crystal under a stress state, $\sigma_x = 250$ psi, $\sigma_y = -50$ psi, $\sigma_z = \tau_{yz} = \tau_{zx} = \tau_{xy} = 0$, where $x = [100]$, $y = [010]$ and $z = [001]$.

A. What is the resolved shear stress, τ_{nd} , on the (111) plane in the $[\bar{1}\bar{1}0]$ direction? i.e. with $n = [111]$, $d = [\bar{1}\bar{1}0]$

B. What is the resolved shear stress on the $(11\bar{1})$ plane in the $[101]$ direction?

Solution A. $\tau_{nd} = \sigma_x l_{xn} l_{xd} + \sigma_y l_{yn} l_{yd} = 250(1/\sqrt{3})(1/\sqrt{2}) + (-50)(1/\sqrt{3})(-1/\sqrt{2}) = 122.5$ psi

B. $\tau_{nd} = \sigma_x l_{xn} l_{xd} + \sigma_y l_{yn} l_{yd} = 250(1/\sqrt{3})(1/\sqrt{2}) + (-50)(1/\sqrt{3})(0/\sqrt{2}) = 102.$ psi

2. Consider the single crystal in problem 1. Now suppose that slip does occur on the (111) plane in the $[\bar{1}0\bar{1}]$ direction and only on that slip system. Also assume that the resulting strains are small.

Calculate the ratios of the resulting strains ϵ_x/ϵ_x and ϵ_z/ϵ_x .

$\epsilon_x = \gamma_{nd}(l_{xn} l_{xd}) = \gamma_{nd}(1/\sqrt{6})$. $\epsilon_y = \gamma_{nd}(l_{yn} l_{yd}) = -\gamma_{nd}(1/\sqrt{6})$,

$\epsilon_z = \gamma_{nd}(l_{zn} l_{zd}) = -\gamma_{nd}(0)$. Therefore $\epsilon_z/\epsilon_x = -1$ and $\epsilon_y/\epsilon_x = 0$.

3. A body is loaded under a stress state, $\sigma_x = 400$, $\sigma_y = 100$, $\tau_{xy} = 120$, $\tau_{yz} = \tau_{zx} = \sigma_z = 0$.

A. Sketch the Mohr's circle diagram.

B. Calculate the principal stresses

C. What is the largest shear stress in the body? (Do not neglect the z direction.)

Solution: A.

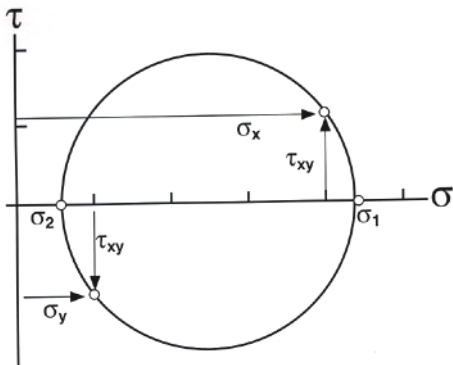

B. $\sigma_1, \sigma_2 = (\sigma_x + \sigma_y)/2 \pm \{[(\sigma_x - \sigma_y)/2]^2 + \tau_{xy}^2\}^{1/2} = 250 \pm [150^2 + 120^2]^{1/2} = 442, 58, \sigma_3 = \sigma_z = 0$.

C. $\tau_{max} = (\sigma_1 - \sigma_3)/2 = 221$.

4. Three strain gauges have been pasted on the surface of a piece of steel in the pattern shown below. While the steel is under load, these gauges indicate the strains parallel to their axes:

Gauge A 450×10^{-6} : Gauge B 300×10^{-6} : Gauge C -150×10^{-6}

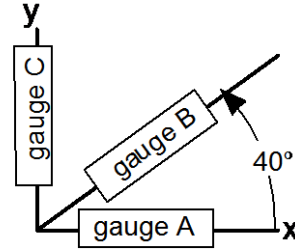

Figure 1.21. Arrangement of strain gauges.

A. Calculate the principal strains ϵ_1 and ϵ_2 .

B. Find the angle between the 1 axis and the x-axis, where 1 is the axis of the largest principal strain? [Hint: Let the direction of gauge B be x' , write the strain transformation equation expressing the strain $e_{x'}$ in terms of the strains along the x-y axes, solve for γ_{xy} and finally use the Mohr's circle equations.]

Solution: A. $\epsilon_B = \epsilon_A \cos^2 40 + \epsilon_C \cos^2 50 + \gamma_{AB} \cos 40 \cos 50 =$
 $300 = 450 \times 0.587 - 150 \times 0.413 + \gamma_{AB} 0.766 \times 0.623$

$\gamma_{AB} = 198,$

$\epsilon_1, \epsilon_2 = (\epsilon_A + \epsilon_C)/2 \pm \{[(\epsilon_A - \epsilon_C)/2]^2 + (\gamma_{xy}/2)^2\}^{1/2} = 150 \pm [300^2 + 198^2]^{1/2} = 509, -209 \times 10^{-6}$

B. $\tan(2\theta) = \gamma_{AB}/(\epsilon_A - \epsilon_B) = 198/600 = 0.33, \theta = \text{atan}(0.33)/2 = 9.1^\circ$

5. Consider a thin-wall tube that is 1 inch in diameter and has a 0.010-inch wall thickness. Let x, y, and z be the axial, tangential (hoop) and radial directions respectively.

A. The tube is subjected to an axial tensile force of 80 lbs. and a torque of 100 in-lbs.

i. Sketch the Mohr's circle diagram showing stresses in the x-y plane.

ii. What is the magnitude of the largest principal stress?

iii. At what angles are the principal stress axes, 1 and 2, to the x and y directions?

B. Now let the tube be capped and let it be subject to an internal pressure of 120 psi and a torque of 100 in-lbs.

i. Sketch the Mohr's circle diagram showing stresses in the x-y plane.

ii. What is the magnitude of the largest principal stress?

iii. At what angles are the principal stress axes, 1 and 2, to the x and y directions?

Solution: A. A torque balance gives $100 \text{ in-lb} = \tau_{xy}(\pi \times 1 \text{ in})(0.010 \text{ in})(0.5 \text{ in}), \tau_{xy} = 100/(0.010 \pi \times 0.5) = 6366 \text{ psi}$. The axial stress, $\sigma_x = 80/[(\pi \times 1 \text{ in})(0.010 \text{ in}^2)] = 2546 \text{ psi}$

i.

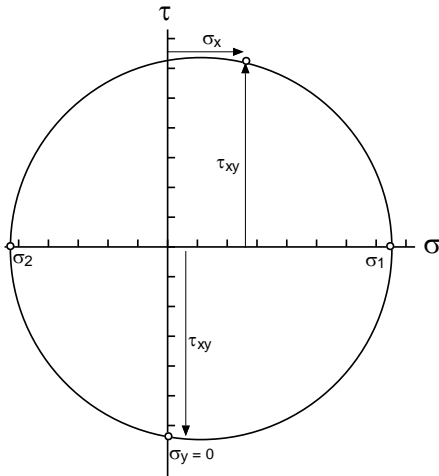

ii. $\sigma_1 = (\sigma_x + \sigma_y)/2 \pm \{[(\sigma_x - \sigma_y)/2]^2 + \tau_{xy}^2\}^{1/2} = 2546/2 + [1273^2 + 6366^2]^{1/2} = 7765 \text{ psi}$

iii. $\tan(2\theta) = 6366/(2546/2) = 5.0, \theta = (0.5)\text{atan}(5.0) = 39.3^\circ, 129^\circ$

B. Now there is a hoop stress, $\sigma_y = Pd/(2t) = 120 \times 1/(2 \times 0.01) = 6000 \text{ psi}$, an axial stress of $\sigma_x = Pd/(4t) = 3000 \text{ psi}$ and a shear stress of 6366 psi.

i.

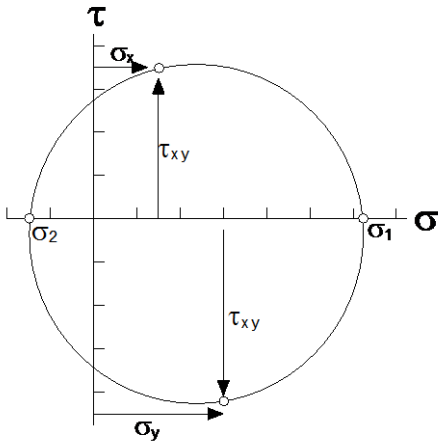

ii $\sigma_1 = (\sigma_x + \sigma_y)/2 + \{[(\sigma_x - \sigma_y)/2]^2 + \tau_{xy}^2\}^{1/2} = 4500 + [1500^2 + 6366^2]^{1/2} = 11,040 \text{ psi}$

iii $\tan(2\theta) = 6366/1500 = 4.244, \theta = (.5)\text{atan}(4.244) = 38.4^\circ, 128.4^\circ$

6. A solid is deformed under plane-strain conditions ($\epsilon_z = 0$). The strains in the x-y plane are $\epsilon_x = 0.010$, $\epsilon_y = 0.005$, and $\gamma_{xy} = 0.007$.

A. Sketch the Mohr's circle diagram.

B. Find the magnitude of ϵ_1 and ϵ_2 .

C. What is the angle between the 1 and x axes?

C. What is the largest shear strain in the body? (Do not neglect the z direction.)

Solution: A

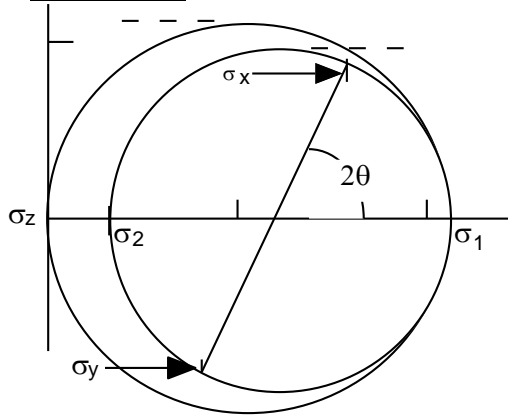

B. $\epsilon_1, \epsilon_2 = (0.010 + 0.005)/2 \pm \{[(0.010 - 0.005)/2]^2 + (0.007/2)^2\}^{1/2} = 0.0118, 0.00320$

C. $\tan(2\theta) = \gamma_{xy}/(\epsilon_x - \epsilon_y) = 0.007/0.005 = 1.4, \theta = (1/2)\text{atan}(0.28) = 27.2^\circ$

D. $\gamma_{\max} = (\epsilon_1 - \epsilon_3) = 0.018$

7. A grid of circles, each 10.00 mm diameter, was etched on the surface of a sheet of steel. When the sheet was deformed the grid circles were distorted into ellipses. Measurement of one indicated that the major and minor diameters were 11.54 and 10.70 mm respectively

A. What are the principal strains, ϵ_1 and ϵ_2 ?

B. If the axis of the major diameter of the of the ellipse makes an angle of 34° to the x-direction, what is the shear strain, γ_{xy} ?

C. Draw the Mohr's strain circle showing $\epsilon_1, \epsilon_2, \epsilon_x,$ and ϵ_y .

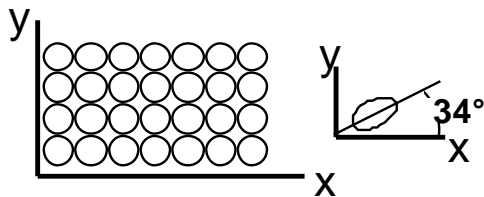

Figure 20. Circle grids printed on a metal Sheet.

Solution:

A. $\epsilon_1 = \ln(1.154) = 0.143 \quad \epsilon_2 = \ln(1.070) = 0.0676$ (or $e_1 = 0.154, e_2 = .07$)

B. $\tan(2\theta) = \gamma_{xy}/(\epsilon_1 - \epsilon_2), \gamma_{xy} = (0.143 - .067)\tan(68^\circ) = 0.188$

C.

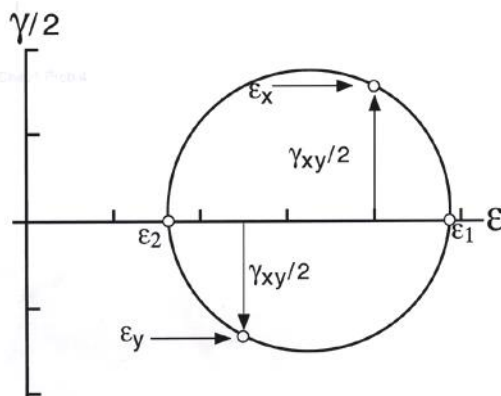

8. Consider an aluminum single crystal under a stress state, $\sigma_x = +75$ psi, $\sigma_y = +25$ psi $\sigma_z = \tau_{yz} = \tau_{zx} = \tau_{xy} = 0$, where $x = [100]$, $y = [010]$, and $z = [001]$.

What is the resolved shear stress, τ_{nd} , on the (111) plane and $[10\bar{1}]$ direction?

Solution: $\tau_{nd} = \sigma_x l_{xn} l_{xd} + \sigma_y l_{yn} l_{yd} = 75(1/\sqrt{6}) + 25(0) = 30.6$ psi.

9. Consider the torsion of a rod that is 1 meter long and 50 mm in diameter.

A. If one end of the rod is twisted by 1.2° relative to the other end, what would be the largest principal strain on the surface?

B. If the rod were extended by 1.2% and its diameter decreased by 0.4% at the same time it was being twisted, what would be the largest principal strain?

Solution; A. $\gamma_{xy} = \tan(1.2^\circ) = 0.0209$, $\epsilon_1 = \gamma_{xy}/2 = .0105$

B. $\epsilon_1 = (\epsilon_x + \epsilon_y)/2 + \{[(\epsilon_x - \epsilon_y)/2]^2 + (\gamma_{xy}/2)^2\}^{1/2} = (.012 - .004)/2 + \{[(.012 + .004)/2]^2 + .0209^2\}^{1/2} = .0253$

10. Two pieces of rod are glued together along a joint whose normal makes an angle, θ , with the rod axis, x . The joint will fail if the shear stress on the joint exceeds its shear strength, τ_{max} . It will also fail if the normal stress across the joint exceeds its normal strength, σ_{max} . The shear strength, τ_{max} , is 80% of the normal strength σ_{max} . The rod will be loaded in uniaxial tension along its axis, and it is desired that the rod carry as high a tensile force, F_x as possible. The angle, θ , cannot exceed 65° .

A. At what angle, θ , should the joint be made so that a maximum force can be carried?

B. If θ_{max} were limited to 45° , instead of 65° , how would your answer be altered? [Hint: plot σ_x/σ_{max} vs. θ for both failure modes.

Figure 1.23. Glued rod.

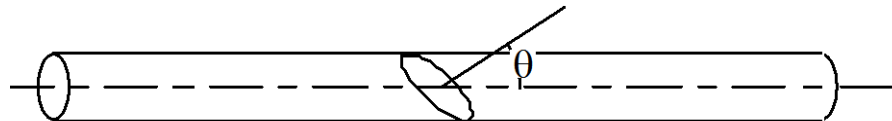

Solution:

Let the axial stress be σ , the max normal stress be $\sigma_{n(max)}$ the max shear stress be $\tau_{(max)}$.

$$\tau_{(max)} = 0.8\sigma_{n(max)}$$

$\sigma_n = \sigma \cos^2 \theta$. Normal failure will occur when $\sigma = \sigma_{n(max)}/\cos^2 \theta$.

$\tau = \sigma \cos \theta \sin \theta$. Shear failure will occur when $\sigma = \tau_{(max)}/\cos \theta \sin \theta = 0.8 \sigma_{n(max)}/\cos^2 \theta$.

Now plotting $\sigma/\sigma_{n(max)}$ vs. θ , it can be seen

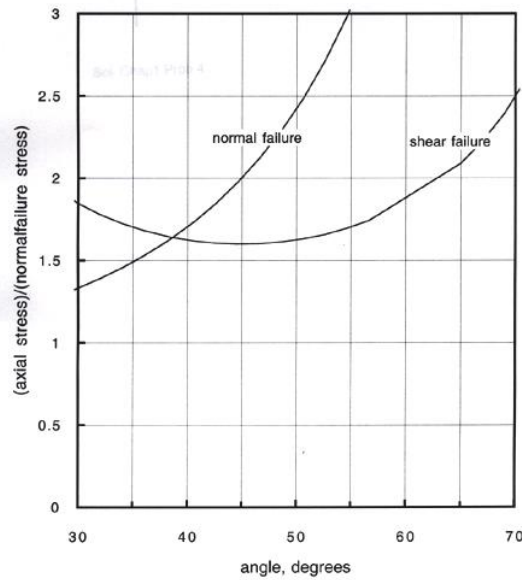

- A. that if $\theta \leq 65^\circ$, the max value of $\sigma_{\max} = 2.089\sigma_{n(\max)}$ at $\theta = 65^\circ$
 B. hat if $\theta \leq 45^\circ$, the max value of σ_{\max} corresponds to the intersection of the two curves and $\sigma_{\max} = 1.64\sigma_{n(\max)}$ at $\theta = 38.65^\circ$

11. Consider a tube made by coiling and gluing a strip as show below. The diameter is 1.5 in., the length is 6 in. and the wall thickness is 0.030 in. If a tensile force of 80 lbs. and a torque of 30 in-lbs. are applied in the direction shown, what is the stress normal to the glued joint? [Hint: Set up a coordinate system]

Figure 22. Tube formed from a coiled and glued strip.

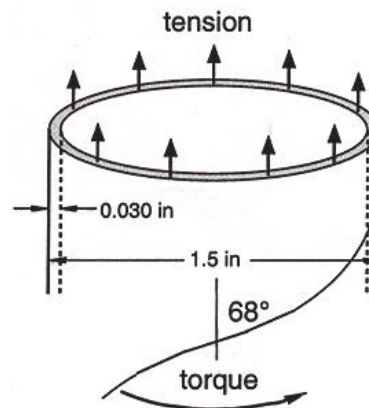

Solution: The torque, $30 \text{ in-lb} = \pi(1.5 \text{ in})(.030 \text{ in})(0.75 \text{ in})\tau_{xy}$.
 $\tau_{xy} = 30 / [\pi(1.5 \text{ in})(.030 \text{ in})(0.75 \text{ in})] = 283 \text{ psi}$, $\sigma_x = 80 \text{ lbs} / [\pi(1.5 \text{ in})(.030 \text{ in})] = 566$
 $\sigma_n = \sigma_x \cos^2 22 - \tau_{xy} \cos 22 \cos 68 = 486$. Note that for the sketch shown, the torque contributes a compressive stress on the joint.